

10A

Slip ring collector



Slip ring collector consisting of rings coupled with brushes, designed for small jib cranes. Compact sized and equipped with 4 rings.

FEATURES

- Suitable for transmitting current with 50/60 Hz supply frequency.
- Extreme temperature resistance: -25°C to +70°C.

OPTIONS

- Available with driving slots.
- Available with coupling flange.

CERTIFICATIONS

- CE and UKCA markings and EAC certification.

CERTIFICATIONS

Conformity to Community Directives	2014/35/UE Low Voltage Directive
	2006/42/CE Machinery Directive
Conformity to UKCA Directives	Supply of Machinery (Safety) Regulations 2008
	Electrical Equipment (Safety) Regulations 2016
Conformity to CE Standards	EN 60204-1 Safety of machinery - Electrical equipment of machines
	EN 60309-1 Plugs, socket-outlets and couplers for industrial purposes - General requirements
	EN 60529 Degrees of protection provided by enclosures
Markings and homologations	CE EAC UKCA

GENERAL TECHNICAL SPECIFICATIONS

Ambient temperature	Storage -40°C/+70°C
	Operational -25°C/+70°C
IP protection degree	IP 00
Insulation category	Class I
Operating positions	Any position

ELECTRICAL SPECIFICATIONS

Rated operational current	10 A
Rated operational voltage	400 Vac
Rated insulation voltage	660 Vac
Max. speed	3 rev./min.
Connections	Faston 6.3 mm

OVERALL DIMENSIONS (mm)

With driving slot

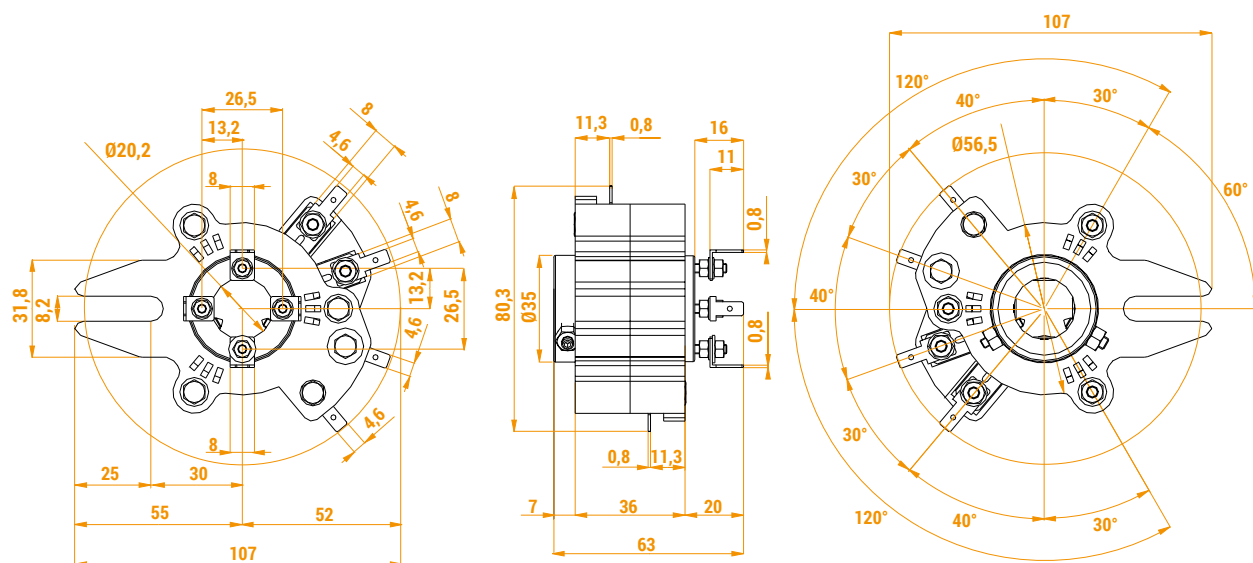

Without driving slot

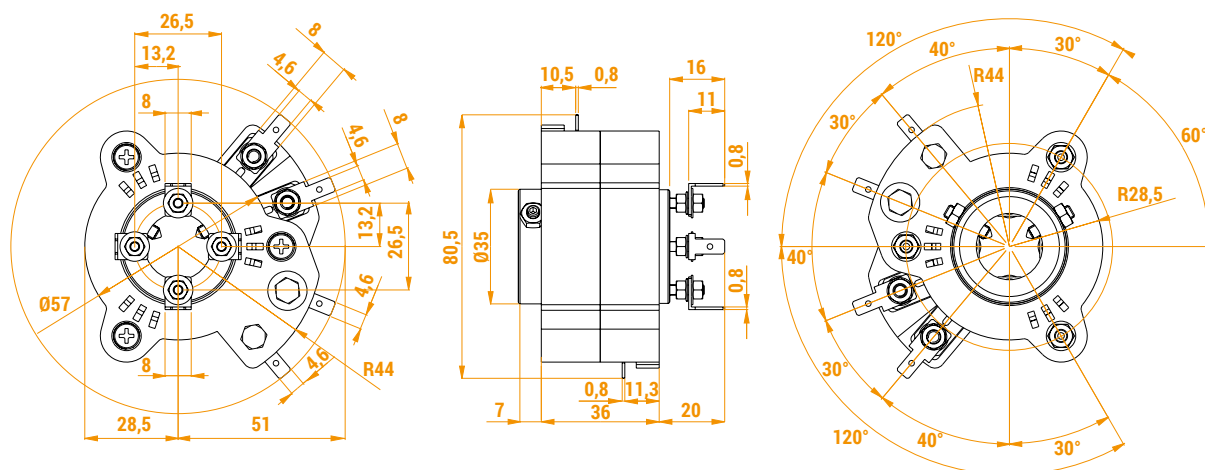

Slip ring collector with $\varnothing 40 \times 30$ mm flange

