

Insulated Enclosure KO 4300S

with twin-level box terminal
for machine soldering technology

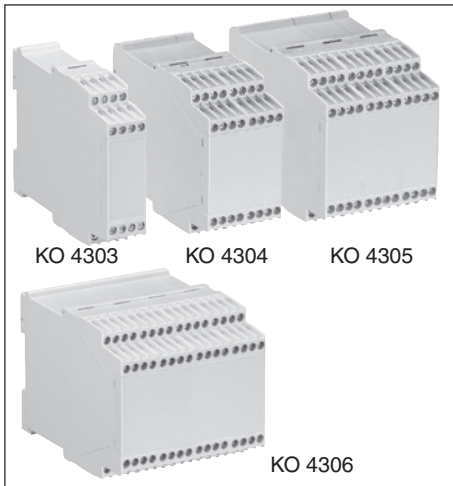

Approvals and Markings



Your Advantages

- modular, flexible
- various connection technologies
- distinctive design
- individual customisation

Features

- Width 22,5 / 45 / 67,5 / 90 mm
- Max. 16 / 32 / 48 / 64 box terminals
- Large, variable front plate surface
- Large cross section of connections possible (e.g. 2 x 1.5 mm² with stranded ferruled)
- Max. current carrying capacity 16 A
- Machine soldered terminal block, use of heat-resistant plastic means no cover for the terminal block facing the soldering bath is required
- Large plus-minus screws enable high tightening torques
- High-voltage test complying with IEC 60 439-1
- Printed circuit board density t = 1.5 mm and 1 mm possible
- More option possible, see "Other options"

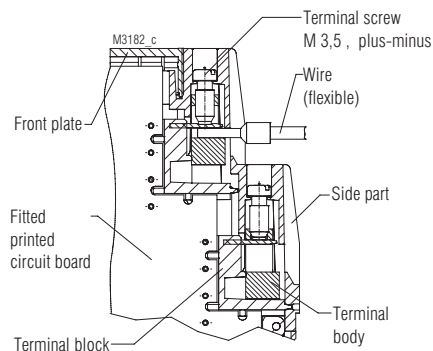

Twin-level box-terminal

Technical Data

Width [mm]	Depth [mm]	Order references	Article-No.:	Version	
22.5	118	KO4303S.	0054998	Standard	
			0066602	UL	
	97	KO4323S.	0054999	Standard	
45	118	KO4304S.	0055738	Standard	
			0066604	UL	
	97	KO4324S.	0055681	Standard	
	67.5	118	KO4305S.	0055671	Standard
				0066606	UL
90	118	KO4306S.	0055682	Standard	
			0066607	UL	
	97	KO4325S.	0055672	Standard	
	97	KO4326S.	0066608	UL	
			0055683	Standard	
			0066609	UL	

Enclosure material:

Standard version:

PC-GF, light gray RAL 7035 (base, side-part and front plate)

PA4/6, natur (terminal block)

UL version:

same as standard, but side-part in

PA66/6, light gray RAL 7035

Temperature stability	PC	PA66/6	PA4/6
complying with UL 746 B:	125 °C	120 °C	120 °C
complying with Vicat ISO 306	Meth. B: 148 °C	230 °C	290 °C
compl. with ISO 75-2	Meth. A: 138 °C Meth. B: 144 °C	225 °C 235 °C	290 °C 290 °C

Max. permitted power dissipation: see diagrams

Specific thermal resistance:

KO 4303S; KO 4304S; KO 4305S: R_{th} = 6.5 K/W; 5.5 K/W; 4.2 K/W

KO 4324S; KO 4324S; KO 4325S: R_{th} = 9.0 K/W; 6.5 K/W; 5.4 K/W

Flame retardancy compl. with UL 94: V-0

Number of terminals

KO 4303S, KO 4323S:

16

KO 4304S, KO 4324S:

32

KO 4305S, KO 4325S:

48

KO 4306S, KO 4326S:

64

} less, on request

Terminal material:

steel strip, tin-plated

Max. cross section for connection

solid / stranded:	AWG	20 - 12	20 - 12
solid / stranded:	mm ²	1 x 0,5 ... 4 / 0,5 ... 4	2 x 0,5 ... 2,5 / 0,5 ... 2,5
stranded ferruled, without or with plastic sleeve	mm ²	1 x 0,5 ... 2,5	2 x 0,5 ... 1,5
stranded twin ferruled and plastic sleeve	mm ²	1 x 0,5 ... 1,5	
stripping length/length of ferrule	mm	8	8

Wire fastening:

Captive plus-minus-terminal screws M3.5 with self raising terminal box

Fixing torque:

max. 0.8 Nm

IEC/EN 60 999-1

Max. contact resistance

10 m Ω

to printed circuit board:

Max. current carrying capacity:

16 A; US: 15 A; CN: 12 A

Inner connection:

Terminal block can be machine soldered;

use of heat-resistant plastic means no cover for the terminal block facing the soldering bath is required

Enclosure fastener:

Snap-on fastener on top hat rail IEC/EN 60 715

Creepage resistance:

Standard version:

CTI 175 ≙ insulating material III a IEC 60 664-1

CTI 250 - 400 ≙ insulating material III a IEC 60 664-1

UL version:

same as standard, but the side-part

CTI 550 ≙ insulating material II IEC 60 664-1

Technical Data

Air gap and creepage distance:	outside: ≥ 6.3 mm inside: ≥ 4.0 mm	IEC 60 664-1 IEC 60 664-1
Type of protection		
Enclosure:	IP 40	IEC 60 529
Terminal strip:	IP 20	IEC 60 529
	contact protection complies with VBG 4	
Print area:		
KO 4303S, KO 4323S:	20.5 x 43.6 mm	
KO 4304S, KO 4324S:	43 x 43.6 mm with one-parted front	
KO 4305S, KO 4325S:	65 x 43.6 mm with one-parted front	
KO 4306S, KO 4326S:	88 x 43.6 mm with one-parted front	
Printed circuit board:	See printed circuit board design	
Printed circuit board holder:	Guide ribs in base	
Other options:	<ul style="list-style-type: none">- Variable equipping level- With ground terminal to top hat rail- Side openings, e. g. for bus connection or ventilation slots- Openings in base, e. g. for bus connection to top hat rail- Variable front plate, optionally with:<ul style="list-style-type: none">* flap cover* openings, depending on customer specification* combination of 22.5 and 45 mm (width)	

**More informationen
see brochure G23**

Dimensions

KO 430_S

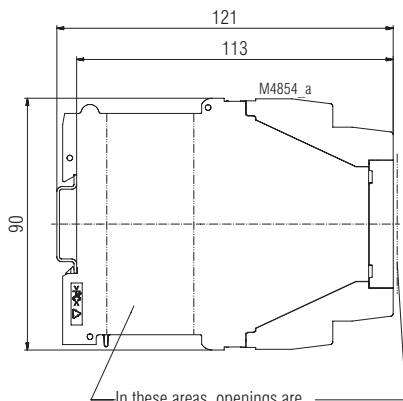

KO 432_S

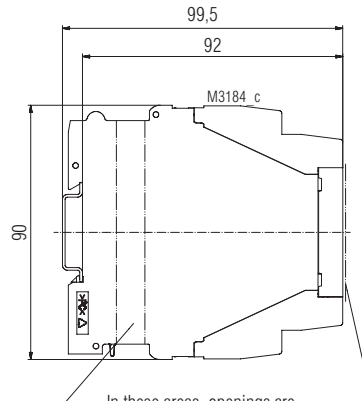

Printed circuit board configuration KO 4303S / KO 4323S

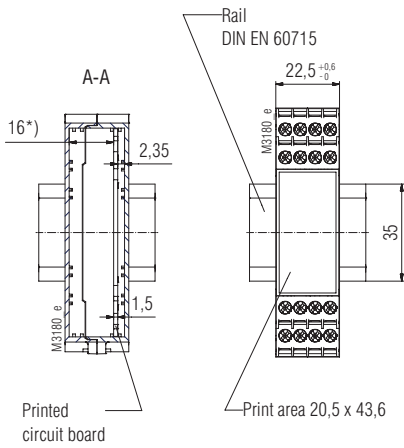

*) 16,5 with printed circuit board thickness $t = 1 \text{ mm}$

Printed circuit board configuration KO 4304S / KO 4324S

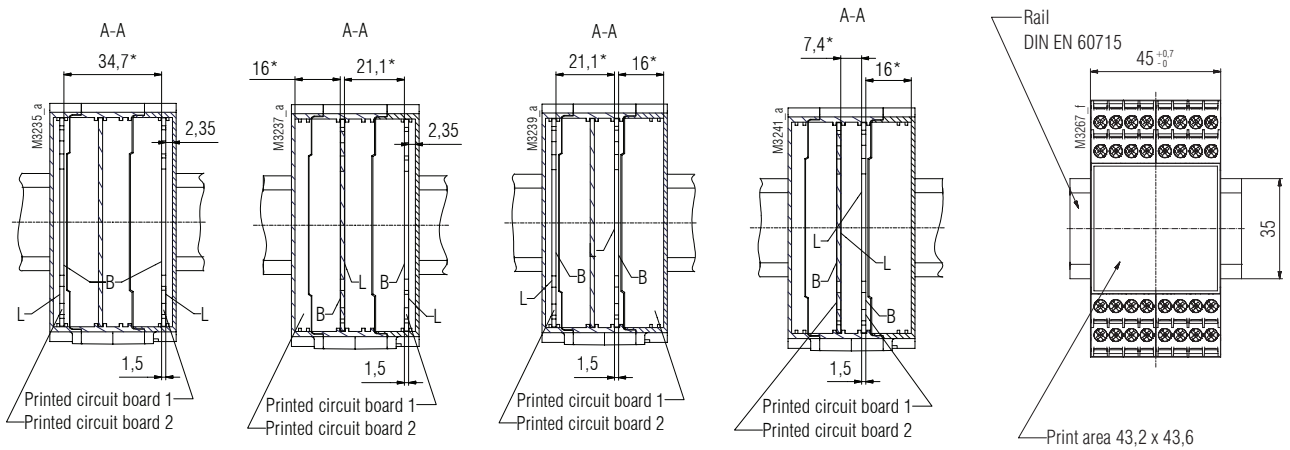

Dimensions

Printed circuit board configuration KO 4305S / KO 4325S

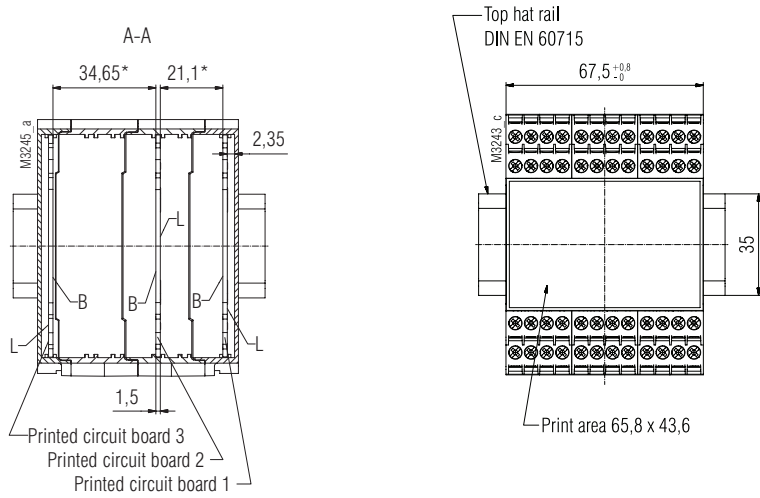

Printed circuit board configuration KO 4306S / KO 4326S

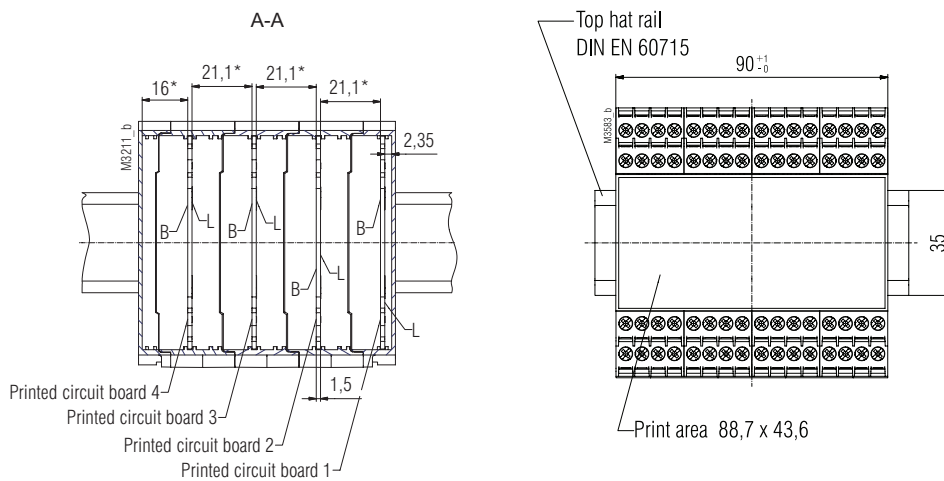

B = Component side
 L = Solder side
 * = max. component height
 Printed circuit board configuration are possible

Printed circuit board design

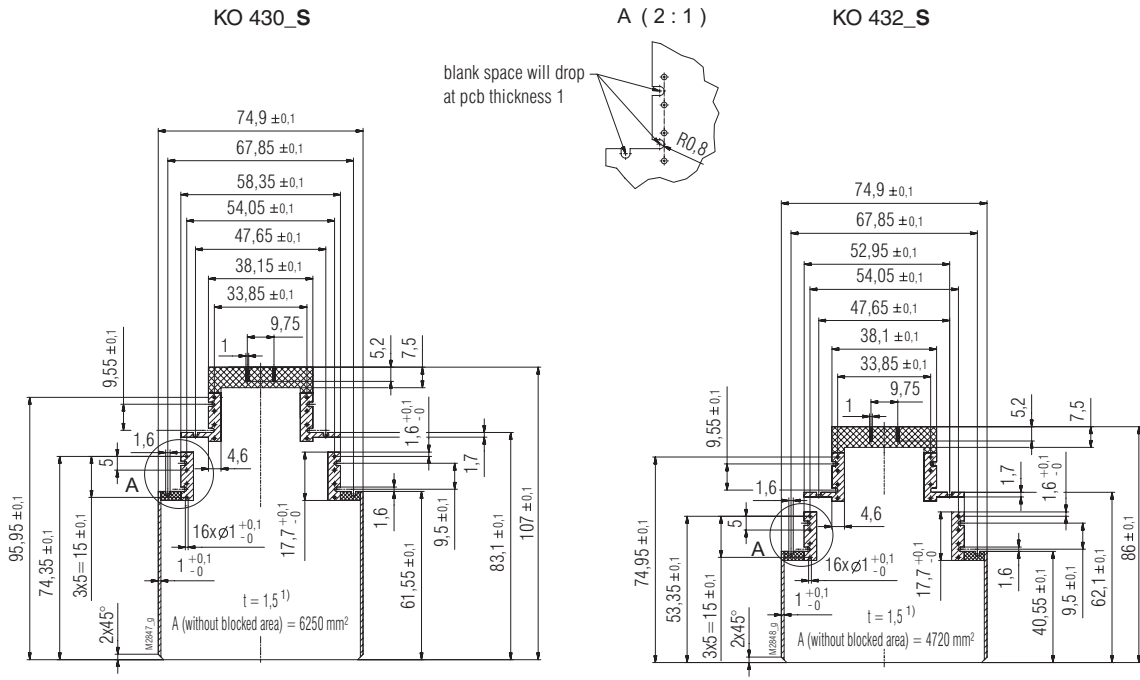

- Land for soldering $\varnothing 2$
 - Blocked area, free of components and conducting material
 - Blocked area
 - Reduced component height (with pcb thickness = 1,5):
 - under side max. 1,65
 - top side max. 15,2
 - under side:
 - Blocked area, free of components
 - top side:
 - Reduced component height max. 14,1 (with pcb thickness = 1,5)
- 1) Tolerance to DIN EN 60249-2-4
 general tolerance : PERFAG 2 E
 Drillings for terminal blocks plated-through 25µm.....50µm

Diagrams (Thermal Resistance)

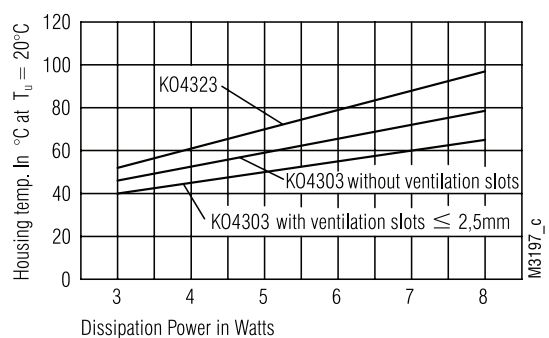

KO 4303S, KO 4323S

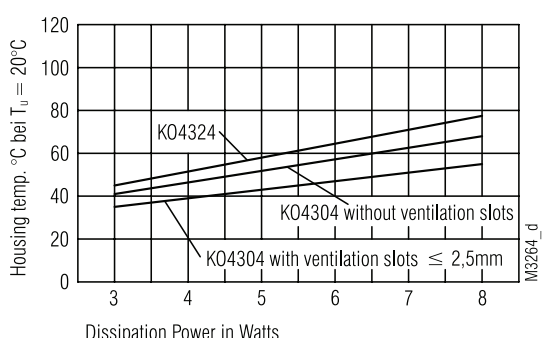

KO 4304S, KO 4324S

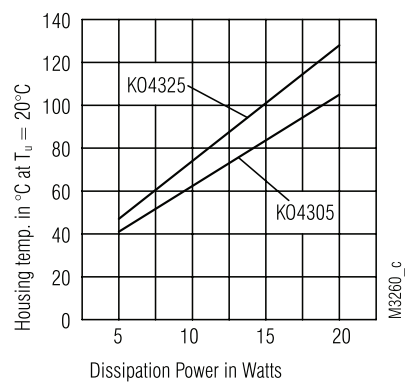

KO 4305S, KO 4325S

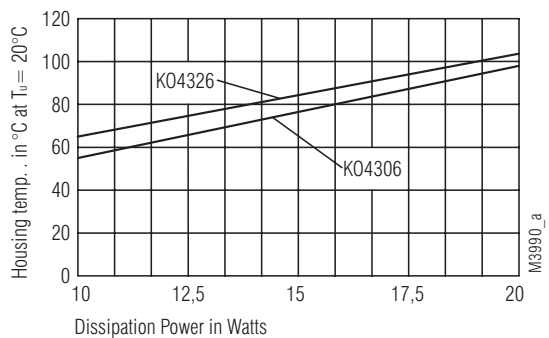

KO 4306S, KO 4326S

Notes on Housing Installation

1. Installation of upper section

- Place all assemblies on a level surface.
- Push the side parts over the terminal blocks of the equipped printed circuit board; in doing so, the guide pins of the terminal blocks must slide into the drilled holes in the side parts
- Snap the front plate onto the premounted side parts

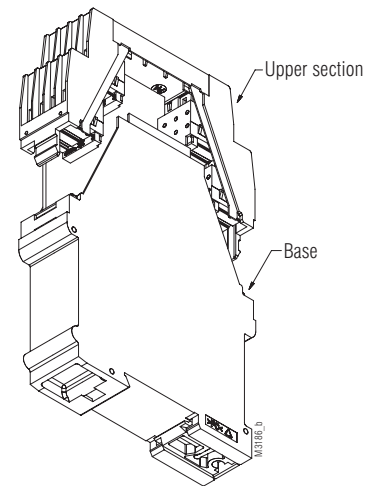
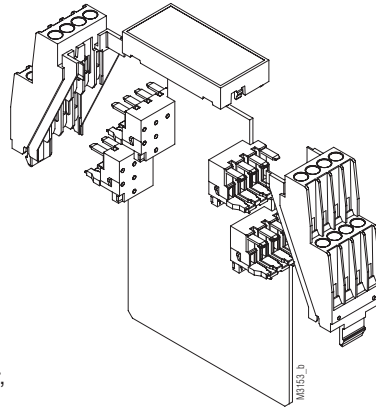
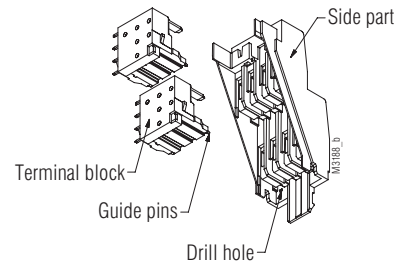

2. Installation of housing

- Place all assemblies on a level surface.
- Slide the printed circuit board of the upper section into the guide grooves of the base.
- When placing the hood and upper section together, ensure that the wall areas overlap correctly. The guide element of the base must slide into the guide recess of the upper section.

Notes on Housing Deinstallation

1. Removing the front plate

- Insert a screwdriver in the side recess of the front plate.
- Turn the screwdriver to the right and left.

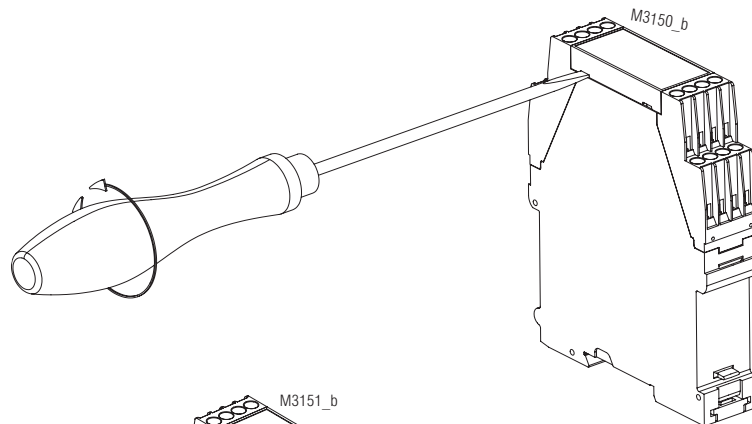

2. Removing the upper section

- Insert a screwdriver in the snap fastener of the base as far as it will go.
- With a tilting movement, release the snap fastening.
- Pull the upper section with the printed circuit board out of the base.

