

PCB series Boosting Cylinder

Product features

CHELIC

Internal structure

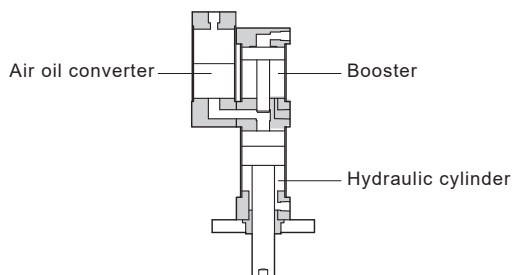
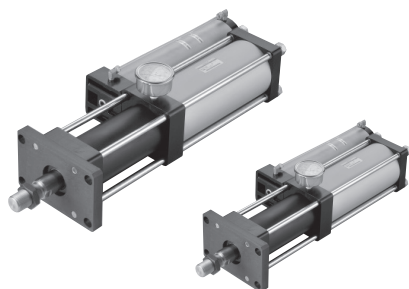

Specification

Item	Bore size	1T	3T	5T	8T	10T	13T	15T	20T
Hydraulic cylinder bore size		Ø63	Ø63	Ø80	Ø80	Ø100	Ø100	Ø125	Ø125
Booster bore size		Ø63	Ø80	Ø100	Ø100	Ø125	Ø125	Ø160	Ø160
Working stroke		5, 10, 15, 20							
Action		Double acting							
Fluid		Air							
Pressure range	Kgf/cm ² (kPa)	2 ~ 7 (200 ~ 700)							
氣缸proof pressure	Kgf/cm ² (kPa)	300 (30000)							
油缸proof pressure	Kgf/cm ² (kPa)	15 (1500)							
Working frequency (max.)	time/s	30				20			
Lubrication		ISO VG68							
Ambient and fluid temperature	°C	-5°C ~ 60°C							
Piston speed	mm/s	50~700							

Boosting cylinder theoretical force

Unit: mm

Thrust model	1T			3T			5T			8T			
Bore size	Ø63			Ø63			Ø80			Ø80			
Piston rod dia	Ø35			Ø35			Ø35			Ø35			
Theoretic force kg	Quick traverse	Intensified feeding	Swift reverse	Quick traverse	Intensified feeding	Swift reverse	Quick traverse	Intensified feeding	Swift reverse	Quick traverse	Intensified feeding	Swift reverse	
Operating force (Kg/cm ²)	1	30	300	20	30	500	20	50	1000	40	50	1250	40
	2	60	600	40	60	1000	40	100	2000	80	100	2500	80
	3	90	900	60	90	1500	60	150	3000	120	150	3750	120
	4	120	1250	80	120	2000	80	200	4000	160	200	5000	160
	5	150	1550	100	150	2500	100	250	5000	200	250	6250	200
	6	180	1850	120	180	3000	120	300	6000	240	300	7500	240
	7	210	2150	140	210	3500	140	350	7000	280	350	8750	280

Thrust model	10T			13T			15T			20T			
Bore size	Ø100			Ø100			Ø125			Ø125			
Piston rod dia	Ø45			Ø45			Ø56			Ø56			
Theoretic force kg	Quick traverse	Intensified feeding	Swift reverse	Quick traverse	Intensified feeding	Swift reverse	Quick traverse	Intensified feeding	Swift reverse	Quick traverse	Intensified feeding	Swift reverse	
Operating force (Kg/cm ²)	1	78	1560	60	78	1970	60	120	2560	90	120	3500	90
	2	156	3120	120	156	3940	120	240	5120	180	240	7000	180
	3	234	4680	180	234	5910	180	360	7680	270	360	10500	270
	4	312	6240	240	312	7880	240	480	10240	360	480	14000	360
	5	390	7800	300	390	9850	300	600	12800	450	600	17500	450
	6	468	9360	360	468	11820	360	720	15350	540	720	21000	540
	7	546	10920	420	546	13790	420	840	17900	630	840	24500	630

Note: Under general usage condition, air supply in 5kg/cm², the output force could reach to 95%.

PCB series Boosting Cylinder

Code of order, Product Precautions

CHELIC

Code of order

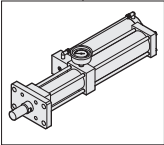
PCB	-	3T	-	100	-	20
Model		Thrust model		Stroke		Working stroke
		1T 10T 3T 13T 5T 15T 8T 20T		50 : 50 mm 100 : 100 mm 150 : 150 mm 200 : 200 mm		5 : 5 mm 10 : 10 mm 15 : 15 mm 20 : 20 mm

Cautions:

1. The booster applicable fluid: Dry and filtered compressed air (Air pressure at 200 ~ 700 kPa).
2. The receiver tank recommends applying in the middle of FRL and booster to have stable air pressure.
3. The suggested circulation oil: ISO VG68.
4. The check regulation valve recommends applying in front of the inlet port of booster pressure.
5. The booster must position higher than the hydraulic cylinder.
 - The booster must position higher than the hydraulic cylinder that allows the air bubble upstraight and exhaust.
 - If the booster position is lower than the actuator, it must exhaust the air bubble from the piping and the actuator before fixing the actuator.
6. To provide clean and dry air to the booster, the FRL unit with auto drain is recommended.
7. The flange is a necessary spare part that mounts the booster on equipment.

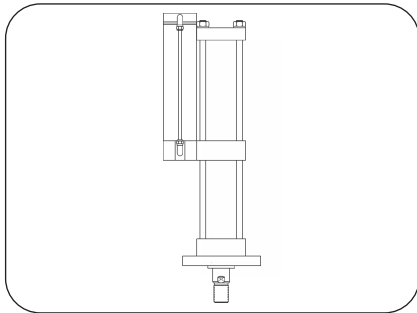

● Image 1: Vertical mounting

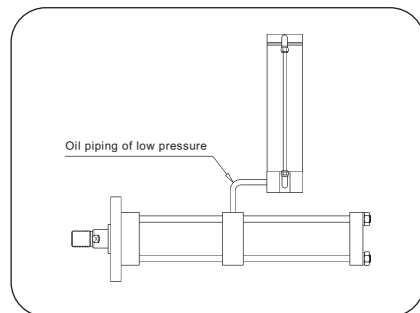

● Image 2: Horizontal mounting - the oil converter must be still vertical

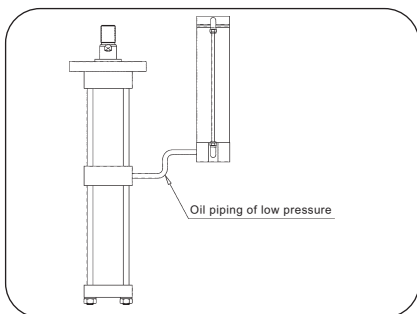

● Image 3: Upside down mounting - the oil converter must be still vertical

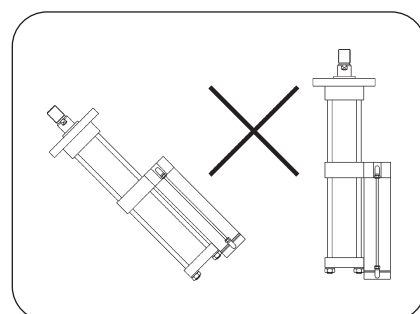

● Image 4: Incline, leaning or oil converter upside down must prohibit.

DC

DH

PCB

PCU

PCB series - Boosting cylinder

Instructions

CHELIC

Booster circuit propose

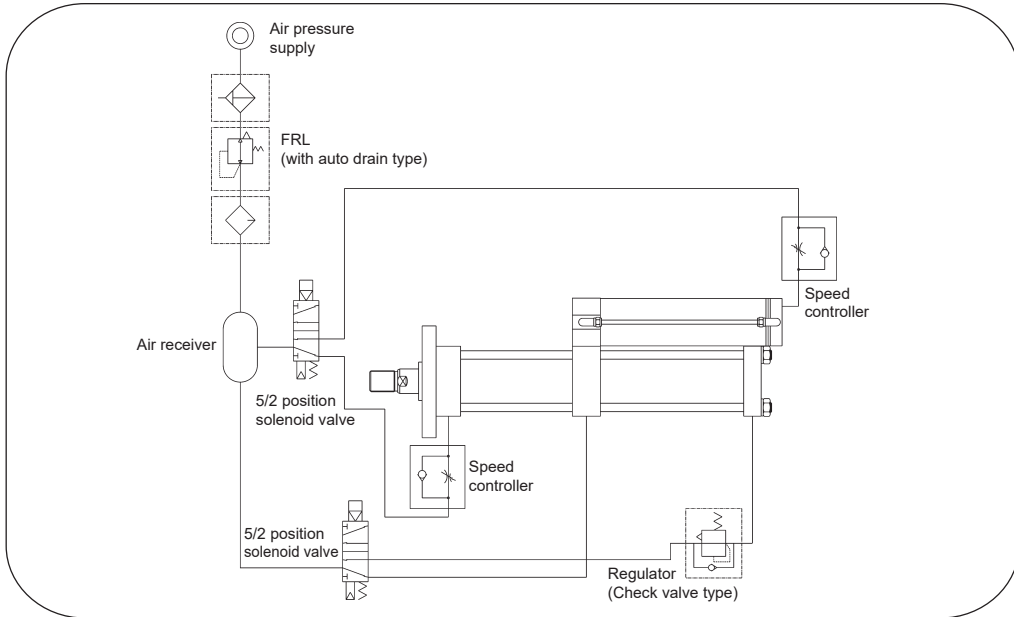

Booster introduction

The booster is a device combines hydraulic and booster that applies air pressure as the power source. Utilize the proportional size of cross-sectional area of booster piston to increase low pressure dozens of times to perform like hydraulic high output force.

Working sequence

① Quick traverse:

P4: Air in, P1: Exhaust,
D2: Go down

② Intensified feeding:

P3: Air in, P2: Exhaust,
D1: Piston go down to
increase pressure

③ Swift reverse:

P1 and P2: Air in,
P3 and P4: Exhaust, then piston go
back to "start" position.

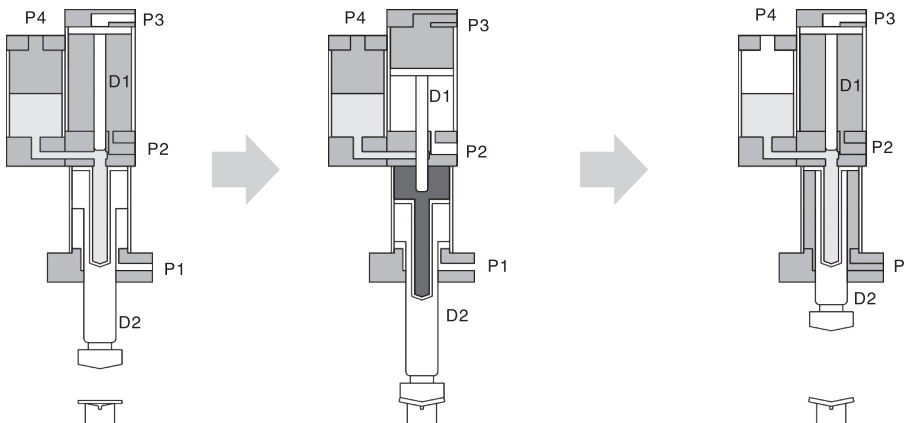

PCB series Boosting Cylinder

Instructions

CHELIC

● The difference of Single pressure type and Dual pressure type

The dual pressure type has two strokes. The first stroke is for low-pressure movement by pushing the oil cylinder to the objects (the circulation oil push to the cylinder), and then the second high-pressure movement (to press the object). The single pressure type has only one stroke with one high-pressure action.

The dual pressure type has a longer stroke with 10 ~ 200 mm in low-pressure stroke distance and 5 ~ 20 mm in high-pressure stroke distance. The single pressure type has a short stroke that has 5 ~ 20 mm high-pressure stroke distance.

Please refer to dual pressure type working theory. The single pressure type working theory as following:

● High pressure pushing (increase pressure force)

● Swift reverse (pneumatic pressure pushing)

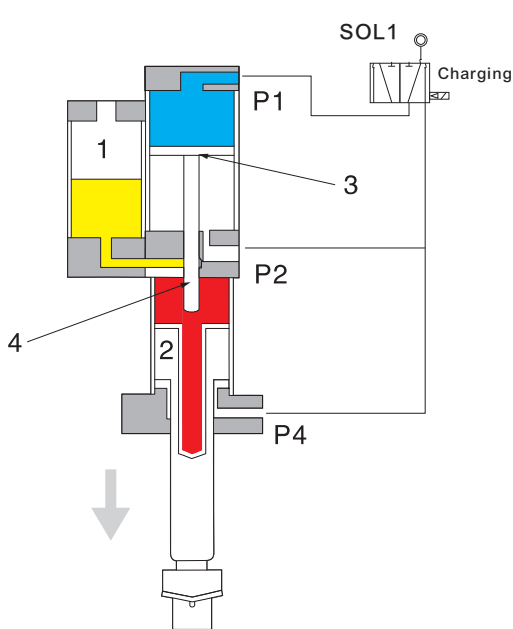

The compressed air flows to P1 via SOL1 (the solenoid valve) of the cylinder to push piston 3 and increase plug 4 to hydraulic cylinder to extrusion the oil to increase the high-pressure force. The high-pressure stroke distance is about 5 ~ 20 mm.

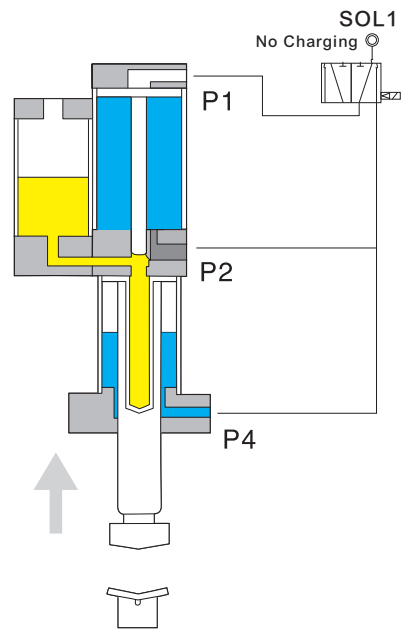

When SOL1 (the solenoid valve) discharge, compressed air through P2 and P4 into the booster and push hydraulic cylinder and booster return swiftly. The pull force is the pneumatic air push force.

DC

DH

PCB

PCU

PCB series - Boosting cylinder

Instructions

CHELIC

☉ The difference of booster, hydraulic cylinder and pneumatic cylinder

Below is the example of hydraulic cylinder, the pneumatic cylinder, and cross-sectional booster area applied Ø63 booster's specification. The PCB-3T-100-20 pneumatic pressure at 6kg/cm² is 187 kg, and the booster force is 2,976kg. When hydraulic pressure at 96kg/cm², the force is at 2,976kg.(must apply with the hydraulic system)

● Booster

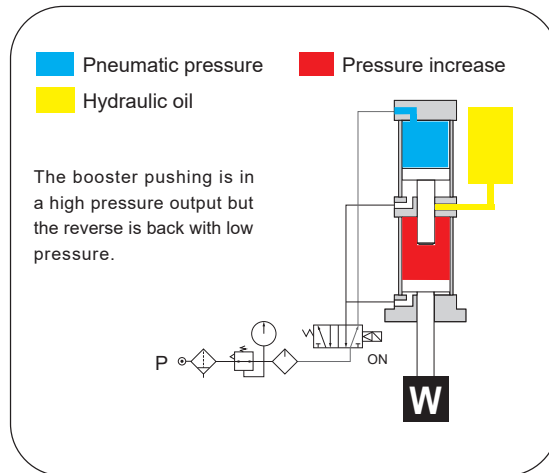

● Pneumatic cylinder

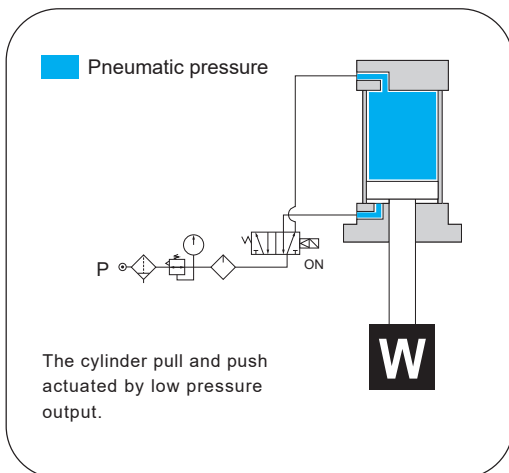

● Hydraulic cylinder

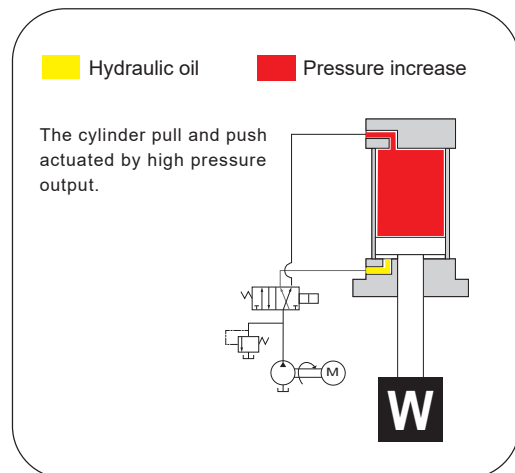

PCB series Boosting Cylinder

Application example

CHELIC

Application example

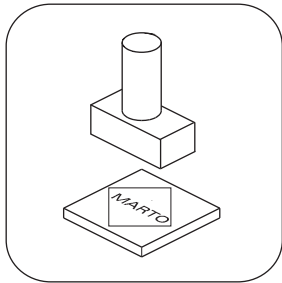

Mark

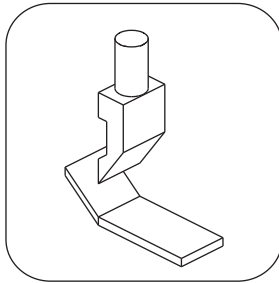

Bend

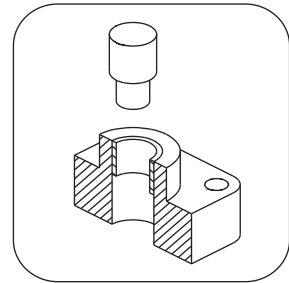

Assemble

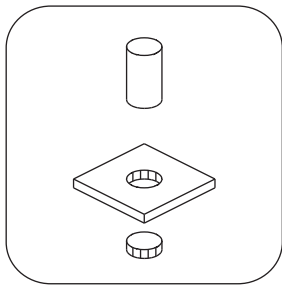

Blank

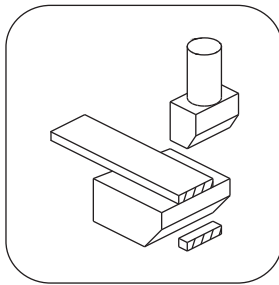

Deburr

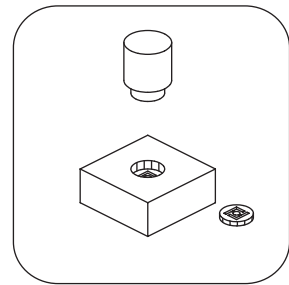

Extrusion

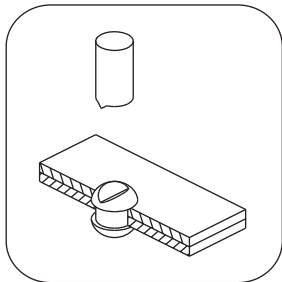

Stake

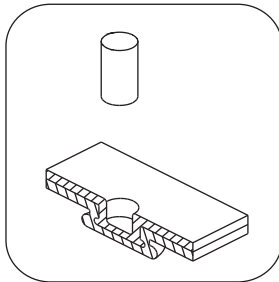

Fold

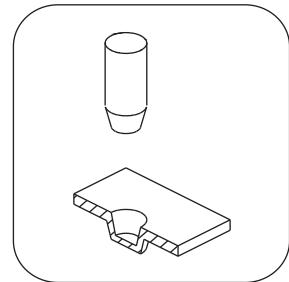

Press

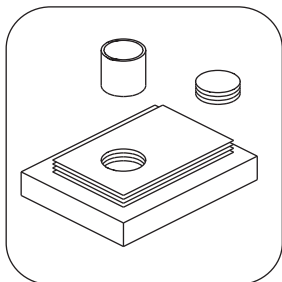

Cut

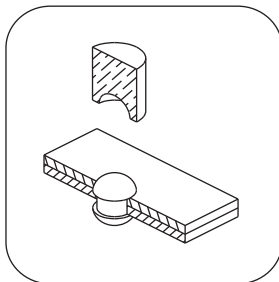

Rivet

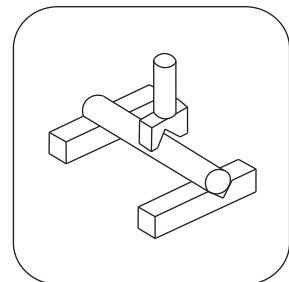

Straighten

DC

DH

PCB

PCU

PCB series Boosting Cylinder

Dimensions

CHELIC

PCB-1T

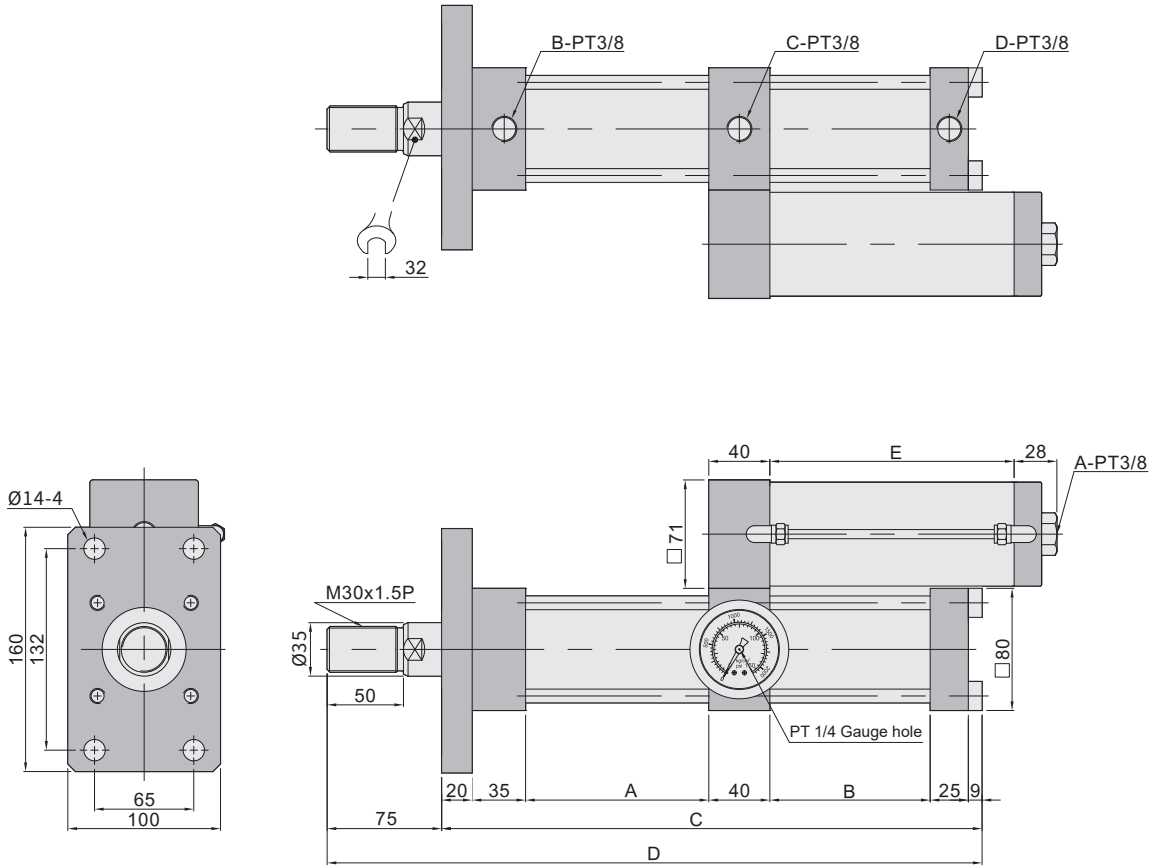

Dimension

Unit: mm

Total stroke	Working stroke	A	B	C	D	E	Total stroke	Working stroke	A	B	C	D	E
50	05	110	105	345	420	240	50	15	110	200	440	515	240
100	05	160	105	395	470	280	100	15	160	200	490	565	280
150	05	210	105	445	520	320	150	15	210	200	540	615	320
200	05	260	105	495	570	360	200	15	260	200	590	665	360
50	10	110	155	395	470	240	50	20	110	250	490	565	240
100	10	160	155	445	520	280	100	20	160	250	540	615	280
150	10	210	155	495	570	320	150	20	210	250	590	665	320
200	10	260	155	545	620	360	200	20	260	250	640	715	360

PCB series Boosting Cylinder

Dimensions

CHELIC

PCB-3T

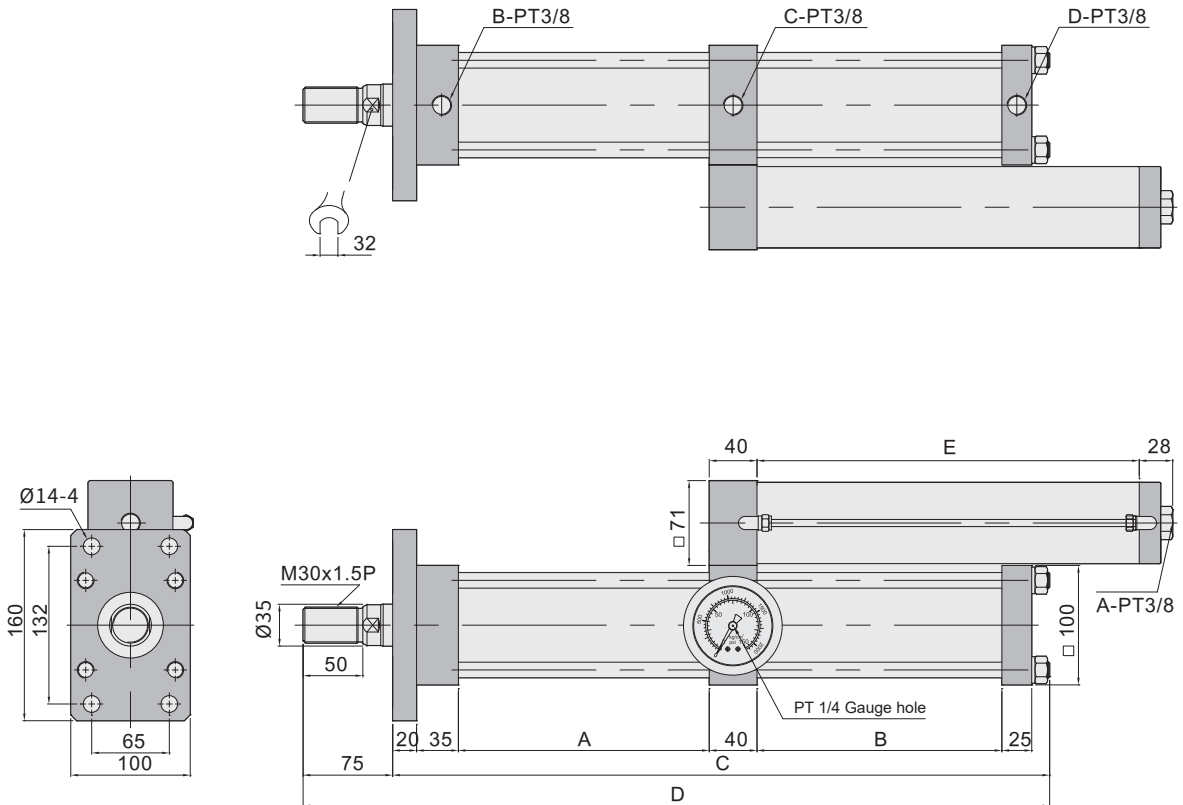

DC

DH

PCB

PCU

Dimension

Unit: mm

Total stroke	Working stroke	A	B	C	D	E	Total stroke	Working stroke	A	B	C	D	E
50	05	110	110	355	430	240	50	15	110	205	450	525	240
100	05	160	110	405	480	280	100	15	160	205	500	575	280
150	05	210	110	455	530	320	150	15	210	205	550	625	320
200	05	260	110	505	580	360	200	15	260	205	600	675	360
50	10	110	160	405	480	240	50	20	110	255	500	575	240
100	10	160	160	455	530	280	100	20	160	255	550	625	280
150	10	210	160	505	580	320	150	20	210	255	600	675	320
200	10	260	160	555	630	360	200	20	260	255	650	725	360

PCB series Boosting Cylinder

Dimensions

CHELIC

PCB-5T

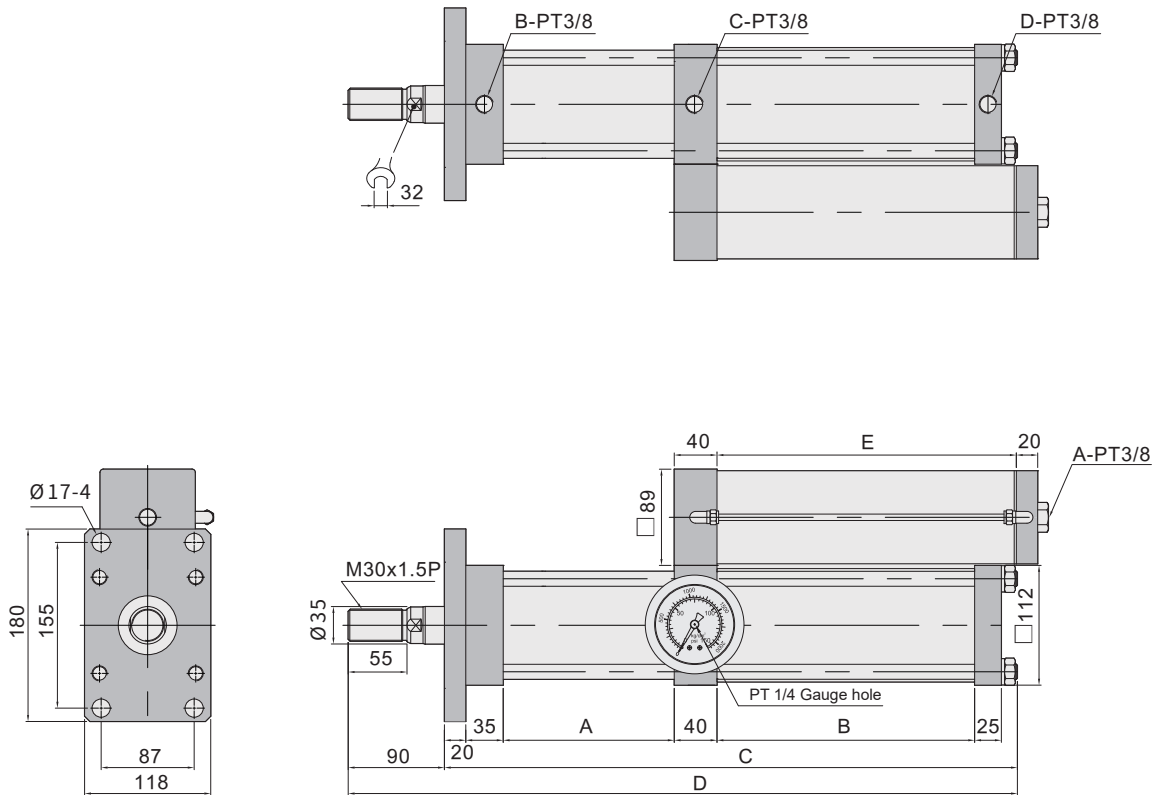

Dimension

Unit: mm

Total stroke	Working stroke	A	B	C	D	E	Total stroke	Working stroke	A	B	C	D	E
50	05	110	121	366	456	220	50	15	110	241	486	576	220
100	05	160	121	416	506	280	100	15	160	241	536	626	280
150	05	210	121	466	556	320	150	15	210	241	586	676	320
200	05	260	121	516	606	360	200	15	260	241	636	726	360
50	10	110	181	426	516	220	50	20	160	301	596	686	220
100	10	160	181	476	566	280	100	20	160	301	596	686	280
150	10	210	181	526	616	320	150	20	210	301	646	736	320
200	10	260	181	576	666	360	200	20	260	301	696	786	360

PCB series Boosting Cylinder

Dimensions

CHELIC

PCB-8T

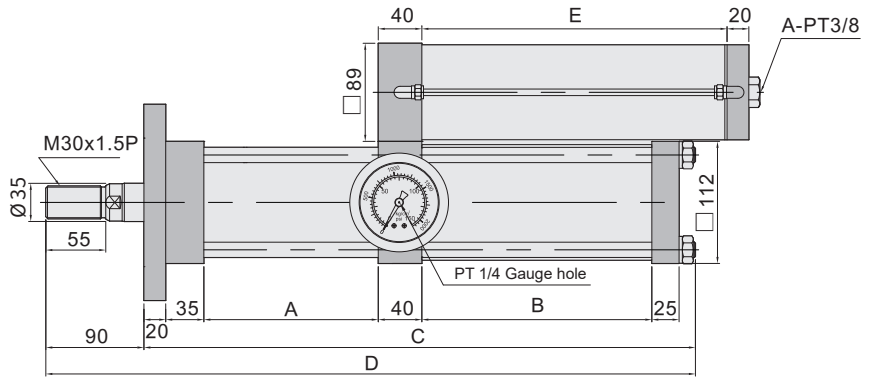
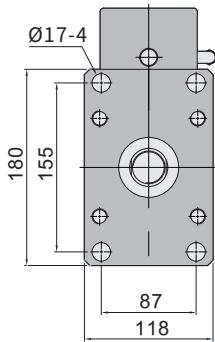
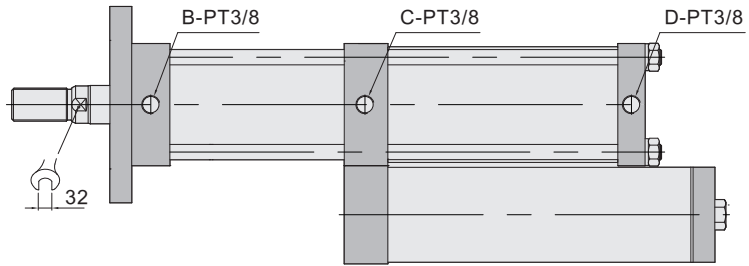

DC

DH

PCB

PCU

Dimension

Unit: mm

Total stroke	Working stroke	A	B	C	D	E	Total stroke	Working stroke	A	B	C	D	E
50	05	110	131	376	466	220	50	15	160	301	596	686	220
100	05	160	131	426	576	280	100	15	160	301	596	686	280
150	05	210	131	476	566	320	150	15	210	301	646	736	320
200	05	260	131	526	616	360	200	15	260	301	696	786	360
50	10	110	211	456	546	220	50	20	270	385	790	880	220
100	10	160	211	506	596	280	100	20	260	385	780	870	280
150	10	210	211	556	646	320	150	20	260	385	780	870	320
200	10	260	211	606	696	360	200	20	260	385	780	870	360

PCB series Boosting Cylinder

Dimensions

CHELIC

PCB-10T

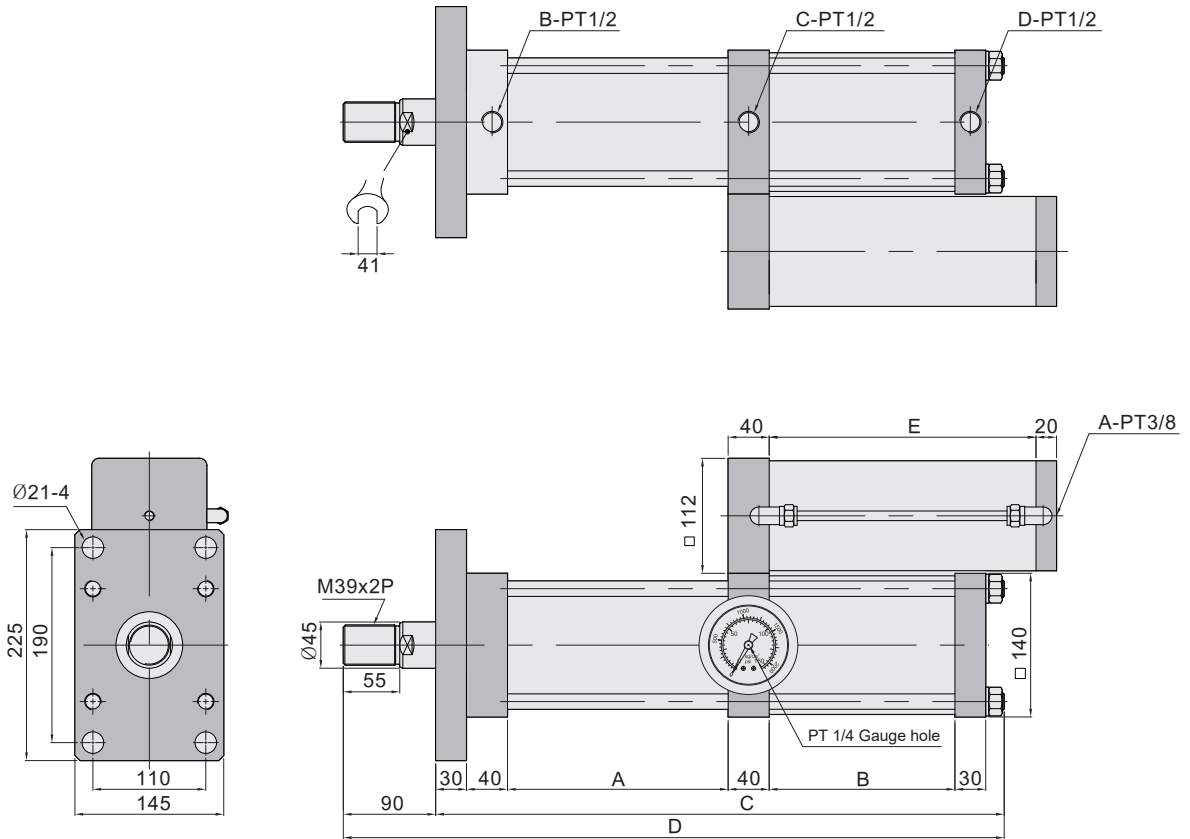

Dimension

Unit: mm

Total stroke	Working stroke	A	B	C	D	E	Total stroke	Working stroke	A	B	C	D	E
50	05	115	121	395	485	220	50	15	115	241	515	605	220
100	05	165	121	445	535	280	100	15	165	241	565	655	280
150	05	215	121	495	585	320	150	15	215	241	615	705	320
200	05	265	121	545	635	360	200	15	265	241	665	755	360
50	10	115	181	455	545	220	50	20	165	301	625	715	220
100	10	165	181	505	595	280	100	20	165	301	625	715	280
150	10	215	181	555	645	320	150	20	215	301	675	765	320
200	10	265	181	605	695	360	200	20	265	301	725	815	360

PCB series Boosting Cylinder

Dimensions

CHELIC

PCB-13T

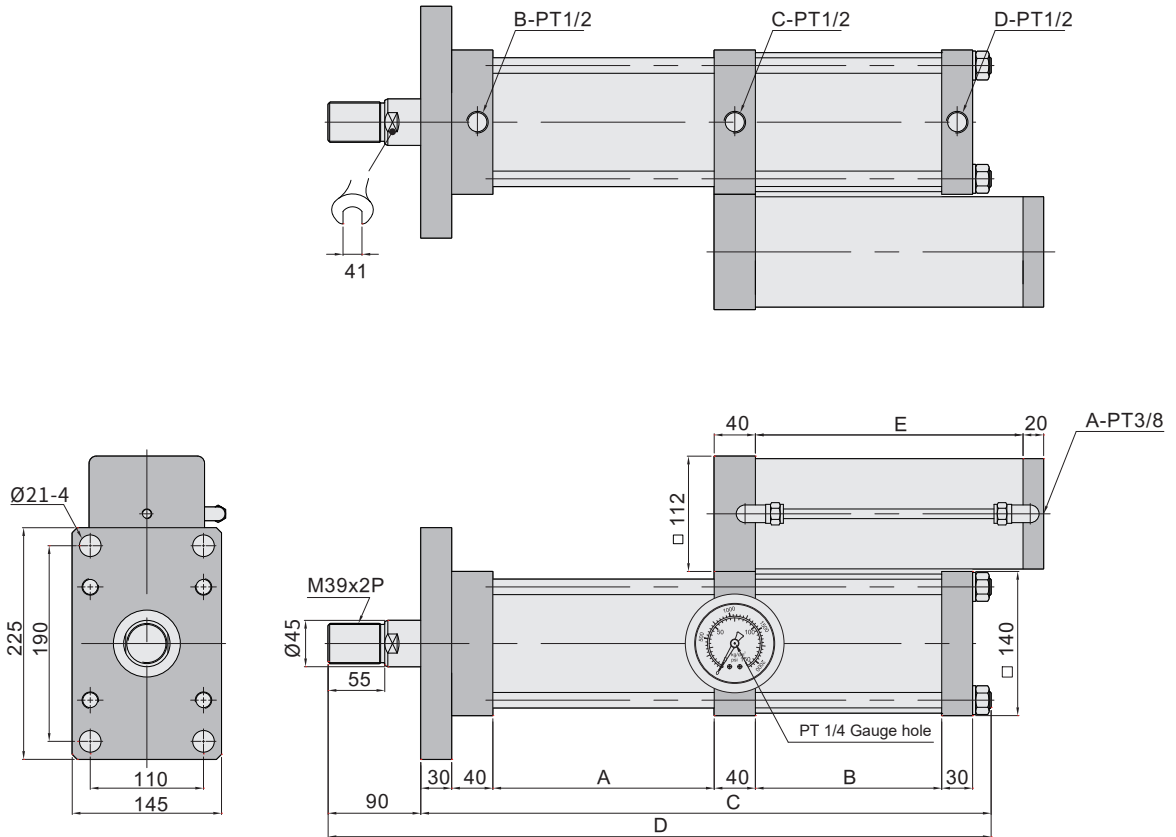

DC

DH

PCB

PCU

Dimension

Unit: mm

Total stroke	Working stroke	A	B	C	D	E	Total stroke	Working stroke	A	B	C	D	E
50	05	115	131	405	495	220	50	15	115	291	565	655	220
100	05	165	131	455	545	280	100	15	165	291	615	705	280
150	05	215	131	505	595	320	150	15	215	291	665	755	320
200	05	265	131	555	645	360	200	15	265	291	715	805	360
50	10	115	211	485	575	220	50	20	215	371	745	835	220
100	10	165	211	535	625	280	100	20	215	371	745	835	280
150	10	215	211	585	675	320	150	20	215	371	745	835	320
200	10	265	211	635	725	360	200	20	265	371	795	885	360

PCB series Boosting Cylinder

Dimensions

CHELIC

PCB-15T

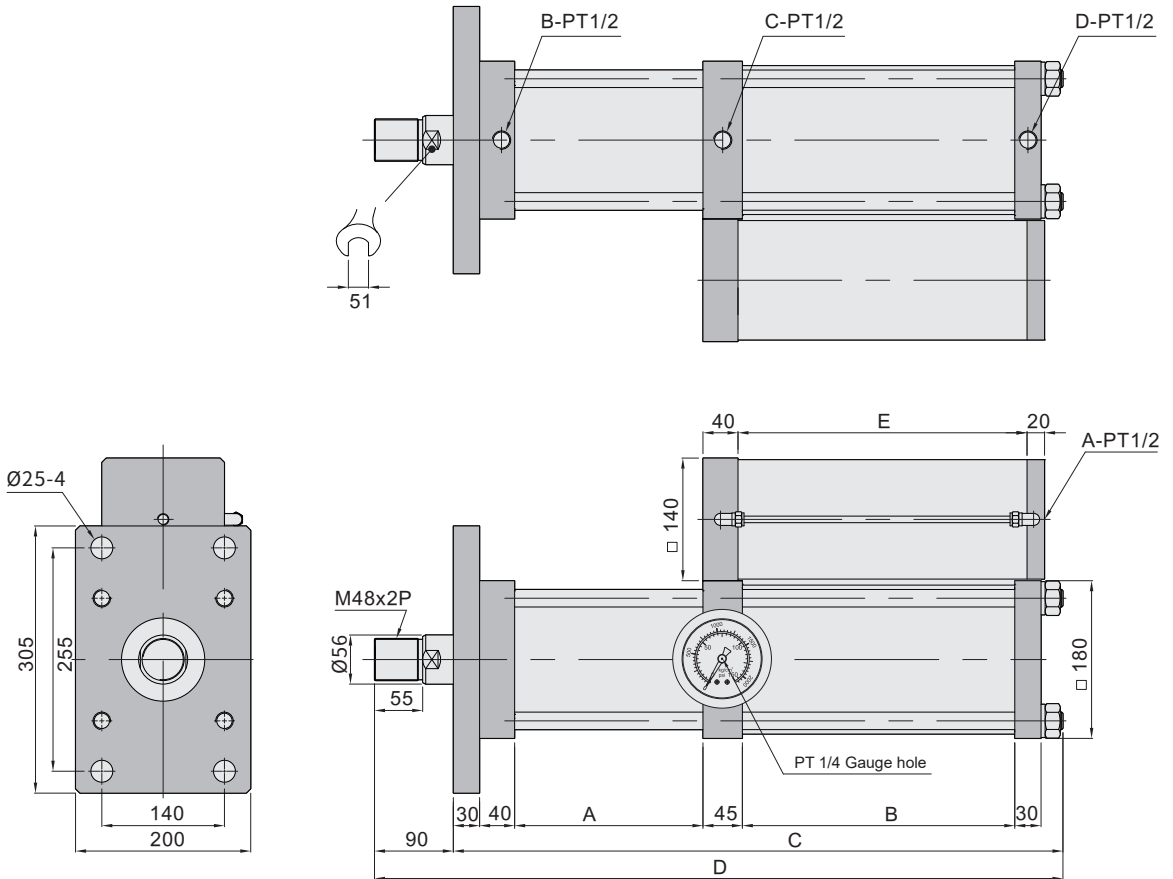

Dimension

Unit: mm

Total stroke	Working stroke	A	B	C	D	E	Total stroke	Working stroke	A	B	C	D	E
50	05	115	131	416	506	220	50	15	115	251	536	626	220
100	05	165	131	466	556	280	100	15	165	251	586	676	280
150	05	215	131	516	606	320	150	15	215	251	636	726	320
200	05	265	131	566	656	360	200	15	265	251	686	776	360
50	10	115	191	476	566	220	50	20	165	311	646	736	220
100	10	165	191	526	616	280	100	20	165	311	646	736	280
150	10	215	191	576	666	320	150	20	215	311	696	736	320
200	10	265	191	626	716	360	200	20	265	311	746	836	360

PCB series Boosting Cylinder

Dimensions

CHELIC

PCB-20T

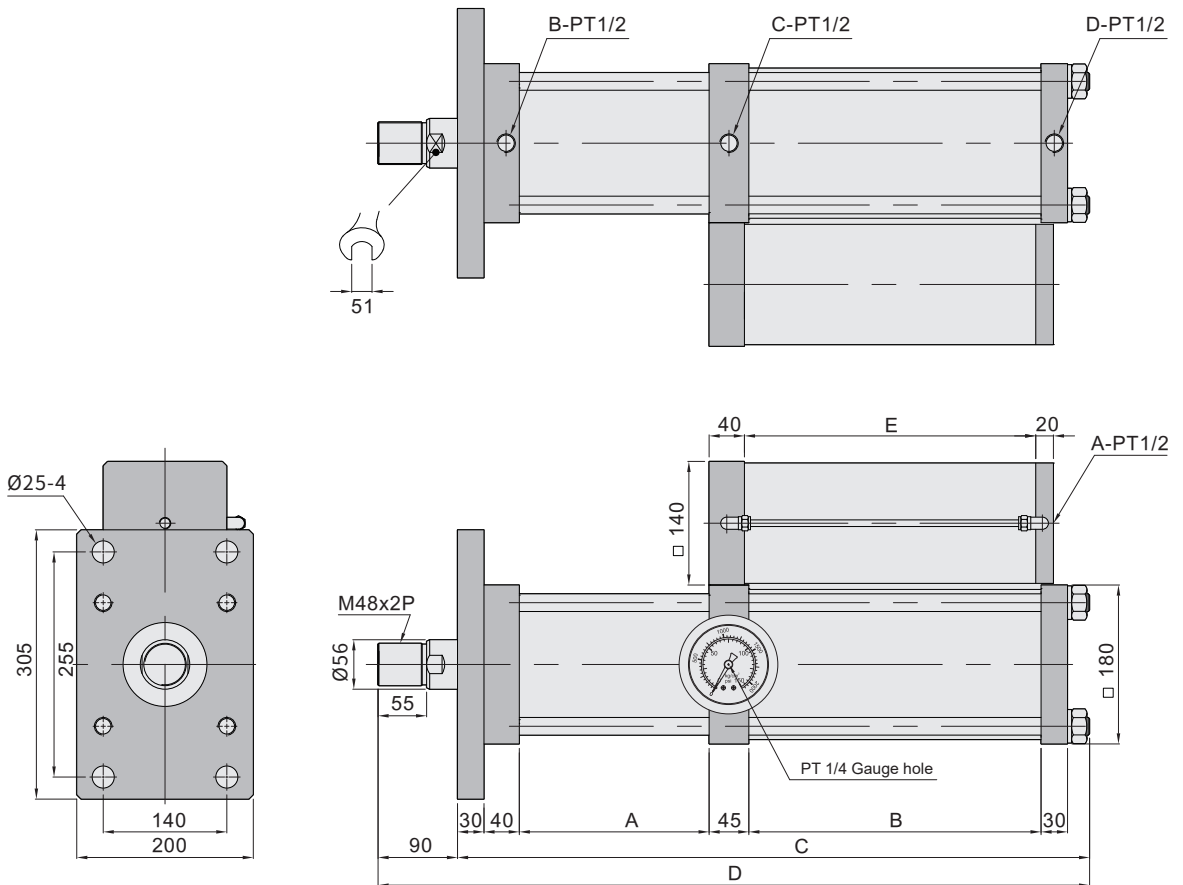

DC

DH

PCB

PCU

Dimension

Unit: mm

Total stroke	Working stroke	A	B	C	D	E	Total stroke	Working stroke	A	B	C	D	E
50	05	115	151	436	526	220	50	15	165	331	666	756	220
100	05	165	151	486	576	280	100	15	165	331	666	756	280
150	05	215	151	536	626	320	150	15	215	331	716	806	320
200	05	265	151	586	676	360	200	15	265	331	766	856	360
50	10	115	241	526	616	220	50	20	265	411	846	936	220
100	10	165	241	576	666	280	100	20	265	411	846	936	280
150	10	215	241	626	716	320	150	20	215	411	796	886	320
200	10	265	241	676	766	360	200	20	265	411	846	936	360

PCB series Boosting Cylinder

Circuit diagram

CHELIC

Quick traverse

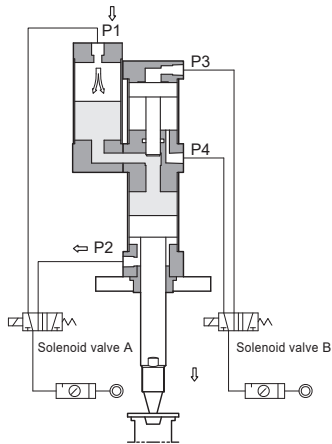

1. When the air is charged from the P1, the oil in the tank will forward the hydraulic cylinder quickly. The pressure is the same as the air pressure, but the inflow of oil is large in volume.

Intensified feeding

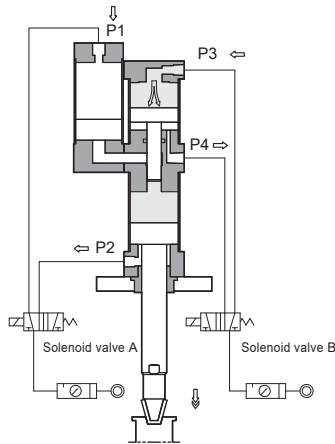

2. When the air is charged from the P3, the ram will advance. The highly pressured fluid will come in to the hydraulic cylinder which will be forwarder by large thrust.

Swift reverse

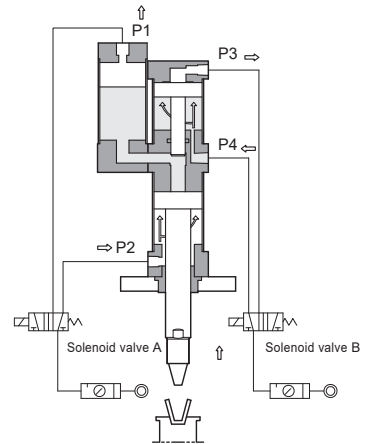

3. When the air is send into port P4 and P2, the hydraulic cylinder is swiftly reversed and at the same time the ram goes down Operating procedure.