

Wall thickness according to AD-2000 code

FOR HIGHER PRESSURES, OTHER SIZES, MATERIALS AND CONNECTION THREAD GAUGES, PLEASE CONSULT

TOLERANCES: External dimensions: ±3% Volume: ±2.5% Weight: ±5%

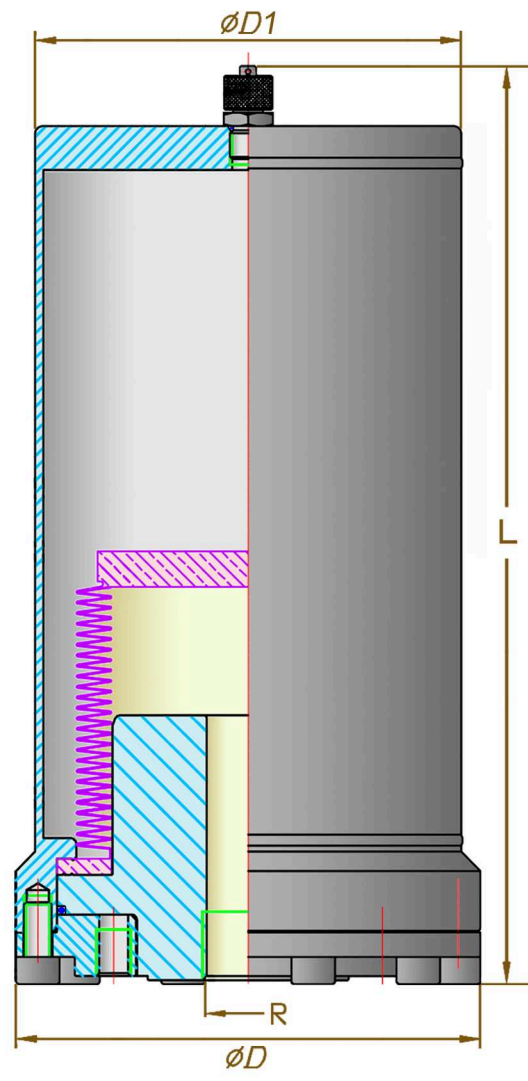

F002 to F007



F015 to F100

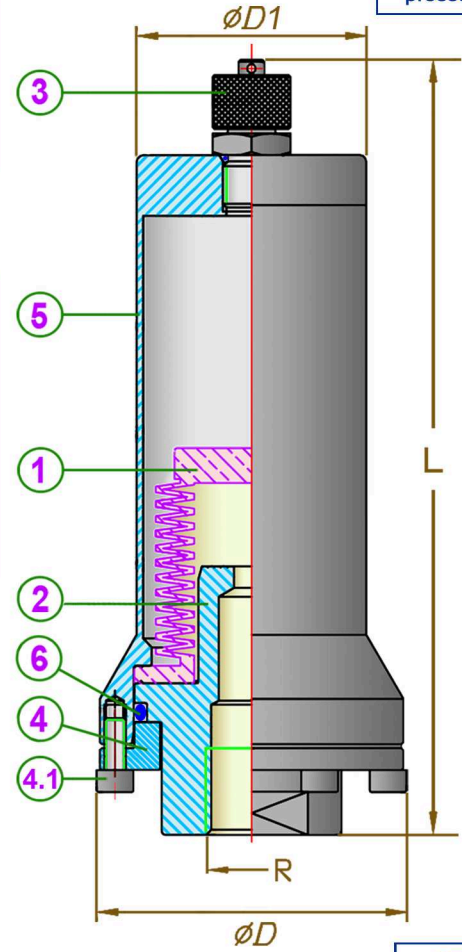

Working temperature versus Working pressure
 A working temperature of 100°C lowers the working pressure x 0.82
 " " " " 150°C " " " " x 0.75
 " " " " 200°C " " " " x 0.68

WORKING TEMPERATURE RANGE: -40 °C / +200 °C

THE MAX. TEMPERATURE CAN GET REDUCED DEPENDING ON THE PROCESS LIQUID

These pulsation dampeners should be filled with gas at 80% of the working pressure and at the working temperature in order to stabilize the flow.

$$\frac{\text{Max. pressure}}{\text{Gas filling pressure}} \leq 2 \text{ (@ constant temperature)}$$

(C = Pump head volume)
 $\Delta V \geq C/2$ for a single head pump
 $\Delta V \geq C/6$ for a duplex head pump
 $\Delta V \geq C/15$ for a three head pump

PULSATION DAMPENER MODEL	MAX. ΔV ADMITTED (c.c.) *	VOLUME (litres)	DESIGN PRESSURE (bar-g @ 20°C)	D (mm)	D1 (mm)	L (mm)	R (BSP)	WEIGHT (kg)	
F002	15	0.15	60	70	53	178	1/2"	1.6	
F003	45	0.30	50	84	64	234		2.2	
F007	120	0.70		105	84	250	3/4"	2.7	
F015	250	1.50	40	123	104	276		7.1	
F030	600	2.60		170	156	306	1"	11.5	
F040		3.80				368		12.1	
F060		5.60				475		12.9	
F100		1,500				10.00		30	250

No.	DENOMINATION	QTY.	MATERIAL
6	SEAL GASKET	1	SILICONE
5	BODY	1	AISI 316L
4.1	BOLTS	7 to 10	DIN 912 A4-70
4	RETAINING NUT	1	AISI 316L
3	GAS CHARGING VALVE	1	AISI 316L (1/4" BSP)
2	NOZZLE	1	AISI 316L
1	BELLOWS	1	PTFE

ATTENTION: MOUNT THE DAMPENER ALWAYS UPRIGHT (w/ #3 VALVE ON TOP)
 IMPORTANT: The pre-charge with nitrogen gas or compressed air must be performed slowly and with the help of our charging tool (ref. BV#A1TM)

ORDER REFERENCE CODE EXAMPLE: F030 A04 T 1 AI

A03 ≡ 30 bar
 A04 ≡ 40 bar
 A05 ≡ 50 bar
 A06 ≡ 60 bar

Capacity: 2.6 litres
 A04 ≡ 40 bar
 T = PTFE bellows
 1" standard connection
 Body and nozzle material: AISI 316L

HIDRACAR S.A.
 Pol. Ind. Bufalvent - c/ Ramón Fargell, 71
 08243 Manresa (Barcelona) - SPAIN
 www.hidracar.com - e-mail: hidracar@hidracar.com
 Tel.: +34 938330252 Fax: +34 93 833 19 50

Customer _____ Customer ref. _____
 Title **PTFE BELLOWS STAINLESS STEEL PULSATION DAMPENERS (All parts in contact with liquid made in PTFE or S.S.)**

Replaces drawing **AFT.AI.BP.IN.DOC. (Rev. 16)**
 Drawing **AFT.AI.BP.IN.DOC.**
 Drawn by **E.Ponsa**
 Approved by **M. Carcaré**
 Rev. **17**
 Date **Nov. 2014**
 Scale **N/A**